



**WACC**  
WESTERN AUSTRALIAN  
COUNTRY CRICKET

GENERAL RULES  
BELT UP COUNTRY CUP  
ANNEXURE A:

**Belt up.**

ONE-DAY (LIMITED OVERS) COMPETITION  
PLAYING CONDITIONS

14<sup>th</sup> July 2023

## CONTENTS

---

DEFINITIONS AND INTERPRETATION .....	4
1. The Players .....	5
2. The Umpires .....	5
3. The Scorers.....	6
4. The Ball.....	6
5. The Bat .....	6
6. The Pitch .....	6
7. The Creases .....	7
8. The Wickets.....	8
9. Preparation and Maintenance of the Playing Area .....	8
10. Covering the Pitch .....	8
11. Intervals .....	8
12. Start of Play; Cessation of Play.....	9
13. Innings.....	9
14. The Follow-on .....	12
15. Declaration and Forfeiture.....	12
16. The Result.....	12
17. The Over.....	13
18. Scoring Runs.....	13
19. Boundaries .....	14
20. Dead Ball .....	14
21. No Ball .....	14
22. Wide Ball .....	14
23. Bye and Leg Bye .....	15
24. Fielder's Absence; Substitutes .....	15
25. Batsman's Innings; Runners .....	15
26. Practice on the Field .....	15
27. The Wicket-keeper .....	15
28. The Fielder .....	15
29. The Wicket is Down.....	17
30. Batsman out of His/Her Ground .....	17
31. Appeals.....	17
32. Bowled .....	17

33.	Caught .....	17
34.	Hit the Ball Twice .....	17
35.	Hit Wicket.....	17
36.	Leg Before Wicket .....	18
37.	Obstructing the Field.....	18
38.	Run Out .....	18
39.	Stumped .....	18
40.	Timed Out .....	18
41.	Unfair Play.....	18
42.	Players' Conduct .....	19
	Appendix 1 – In Event of Delay or Interruption to First Innings .....	20
	Appendix 2 – In Event of Delay or Interruption to Second Innings .....	21
	Appendix 3 – Latest Possible Start Times .....	22
	Spirit of Cricket.....	23

## DEFINITIONS AND INTERPRETATION

---

In these Playing Conditions:

- (a) These playing conditions are to be read together with the CCB General Rules for Country Cup.
- (b) “General Rules” means the “CCB General Rules for Country Cup”.
- (c) Terms also defined in the General Rules will have the same meaning as in the General Rules.
- (d) “One Day Match” means a match played in one day, with one innings per side and a maximum of 50 overs in each innings, in accordance with these Playing Conditions.
- (e) The Laws of Cricket will apply to Country Cup One Day Matches except as altered by these Playing Conditions.
- (f) A reference to a Law or to the Laws of Cricket is a reference to the Laws of Cricket as defined in the General Rules.
- (g) A footnoted reference to or summary of one of more Laws of Cricket is for the assistance of the Players and umpires only, and at all times reference should be made to the text of the Laws of Cricket.
- (h) All references to “Governing Body” within the Laws of Cricket shall be replaced by ‘CCB’.
- (i) “Fielding Restriction Area” is the area defined in playing condition 7.3 below.

# PART A – SETTING UP THE GAME

## 1. THE PLAYERS

---

Law 1 shall apply, subject to the following:

- 1.1 All Players in the match must be qualified to play under the General Rules.
- 1.2 Substitution of players by or for Representative Players will be permitted in accordance with the General Rules.
- 1.3 The colours and design of the clothing shall be uniform for all members of the same team and approved by CCB as per the General Rules.
- 1.4 Players must wear white cricket clothing and spiked footwear as specified in the General Rules except as modified for CCB One Day matches for Senior Competition, where cricket attire must satisfy these requirements:

Clothing article	
Trousers	Coloured/White
Shirts	Coloured
Hats/Helmets	Association
Pullovers	Coloured
Pads or Pad Covers	Coloured/White

## 2. THE UMPIRES

---

Law 2 shall apply, subject to the following:

- 2.1 Law 2.1 is modified as follows:
  - (a) For Qualifying matches: two umpires for each match shall be appointed by the host Association in consultation with appropriate others; and
  - (b) For Finals matches: two umpires for each match shall be appointed by the CCB in consultation with appropriate others.
- 2.2 Law 2.2 is modified as follows: The captains cannot authorise the replacement umpire to stand at the bowler's end.
- 2.3 Law 2.3 is modified as follows: The tea interval cannot be altered and is to be taken between innings.
- 2.4 Law 2.7 and 2.8 shall apply subject to the following:

- (a) The umpires shall disregard any shadow on the pitch from the stadium or from any permanent object on the ground.
- (b) If a shadow from a fielder falls across the striker's half of the pitch, the fielder must remain stationary from the time the bowler commences his run up until the striker has received the ball. In the event of a fielder moving before the striker receives the ball, the umpire shall call and signal "dead ball" if he/she considers the striker has been disadvantaged by the action.

### 3. THE SCORERS

---

Law 3 shall apply, subject to the following:

- 3.1 Law 3.1 is modified as follows: At least one person not involved in the match should be appointed scorer for the match, but where this is not possible, and players are required to score, the team's captain and Club officials are to supervise the recording of the score in the scorebooks.
- 3.2 Clubs must comply with the CCB policies and guidelines published from time to time regarding the keeping of scorebooks and the use of electronic scoring software.
- 3.3 Any player under the age of 17 years at the beginning of the Season must be noted in the scorebook, in accordance with the Under-Age Player Guidelines.
- 3.4 In the event of a dispute about the score at the conclusion of the match, the books or electronic score data should be delivered to the CCB within 2 days of the match to resolve the matter and confirm match points.

### 4. THE BALL

---

Law 4 shall apply, subject to the following:

- 4.1 Approved balls for One Day (Limited Overs) Matches are as per clause 5.6.2 of the General Rules.
- 4.2 Law 4.2.2 shall be replaced by the following: During play umpires shall periodically and irregularly inspect the condition of the ball and shall retain possession of it at the fall of a wicket, a drinks interval, or any other disruption in play.
- 4.3 Law 4.5 shall apply with the following appendage: In the event of a ball becoming wet and soggy as a result of play continuing during inclement weather or it being affected by dew, and in the opinion of the umpires the ball becomes unfit for play, the ball shall be replaced with a ball that has had a similar amount of wear. Either bowler or batsmen may raise the matter with the umpires and the umpires' decision as to a replacement or otherwise will be final.

### 5. THE BAT

---

Law 5 shall apply.

### 6. THE PITCH

---

Law 6 shall apply, subject to the following:

- 6.1 Matches shall be played on such grounds as arranged by the CCB in accordance with the General Rules.
- 6.2 Law 6.4 shall be replaced by the following:
- (a) In the event of a match being abandoned because of inadequate pitch and/or ground preparation, upon the acceptance of the umpires' report the CCB will award the match to the visiting team, or refer the matter to the Tribunal for determination on its behalf.
  - (b) For the purposes of this playing condition, the pitch and/or ground preparation will be deemed to have been inadequate if the match is abandoned as a direct or indirect result of the home Club or any of its employees, contractors or agents failing to take proper precautions in the circumstances to ensure that:
    - (i) The pitch was properly prepared; or
    - (ii) The pitch was properly protected against the elements or other acts of God, vandalism or foul play, machinery or equipment failure or other reasonably foreseeable events.

For the purpose of this rule, a groundsman who is responsible for the preparation of the pitch and who is employed by a body other than the local Club, is deemed to be a contractor or agent of that Club.

- (c) The CCB shall arrange and ensure that a thorough investigation of the circumstances into the abandonment of the match is conducted and that a report be presented to the CCB or Tribunal for decision and penalty if appropriate.

## 7. THE CREASES

---

Law 7 shall apply, subject to the following:

- 7.1 Law 7.3 (the popping crease) shall apply, except that the reference to "a minimum of 6 ft" shall be replaced by "a minimum of 13.71 metres (15 yards)".
- 7.2 For additional crease markings, the following shall apply in addition to Law 7: As a guideline to the umpires for the calling of Wides, the crease markings detailed below shall be marked in white at each end of the pitch.

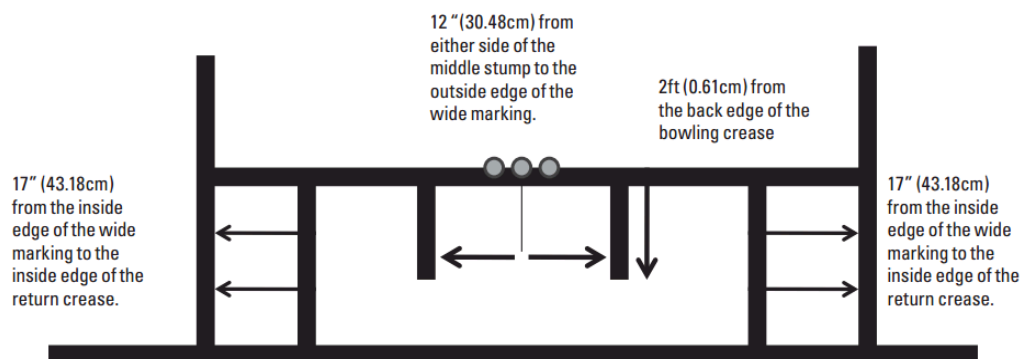

- 7.3 The ground shall be marked with a single fielding restriction area (Fielding Restriction Area) as follows:

- (a) Two semi-circles are drawn on the field of play, with their semi-circles centred on the middle stump of each end of the pitch;
- (b) The radius of each of the semi-circles is 27.43 metres (30 yards);
- (c) The ends of each semi-circle are joined to the other end on the same side of the pitch by a straight line drawn on the field.

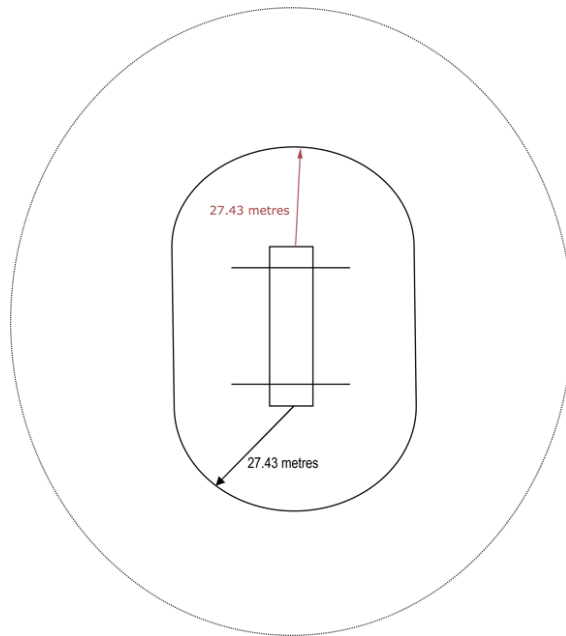

## 8. THE WICKETS

---

Law 8 shall apply, subject to the following:

- 8.1 Law 8.4 (Junior cricket) shall not apply.

## 9. PREPARATION AND MAINTENANCE OF THE PLAYING AREA

---

Law 9 shall apply.

## 10. COVERING THE PITCH

---

Law 10 shall apply.

## 11. INTERVALS

---

Law 11 shall apply, subject to the following:

- 11.1 If the innings of the team batting first is completed before the scheduled time for the interval, the interval shall take place immediately and the innings of the team batting second will commence correspondingly earlier.
- 11.2 The interval between innings will be 30 minutes, but the length of the interval will be reduced to a 20-minute interval if more than 60 minutes of playing time are lost.



- 11.3 The provisions of Law 11.8 (Intervals for drinks) apply except that under conditions of extreme heat the umpires may permit extra intervals for drinks. Drinks breaks may be taken by agreement of the captains (or in the case of the batting side, the batsmen at the wicket), but each drinks break shall not exceed 4 minutes.
- 11.4 Laws 11.2.2, 11.3, 11.5, 11.6 and 11.7 shall not apply.
- 11.5 Law 11.9 shall apply but for only the purpose of the drinks break. Any other intervals shall not be altered.

## 12. START OF PLAY; CESSATION OF PLAY

---

Law 12 shall apply, subject to the following:

- 12.1 There will be two sessions of 195 minutes each separated by an interval as defined by playing condition 11.2 between innings.
- 12.2 Unless advised otherwise by the CCB in the fixtures or otherwise prior to the start of the match, matches will commence at 11.00am and session times will be as follows:

	Session #
11.00am – 2.15pm	Session 1
2.45pm – 6.00pm	Session 2

- 12.3 Laws 12.6, 12.7 and 12.8 do not apply.
- 12.4 Laws 12.9, 12.10 and 12.11 shall apply in so far as they are relevant to a one innings limited overs type match.

# PART B: INNINGS AND RESULT

## 13. INNINGS

---

Law 13 shall apply, subject to the following:

- 13.1 Law 13.1 shall be replaced by the following: All matches shall consist of one innings per side, each innings being limited to a maximum of 50 overs. All matches shall be of one day's scheduled duration.
- 13.2 Law 13.2 (Alternate innings) shall not apply.
- 13.3 Laws 13.3.3 (Declaration), 13.3.4 (Forfeit) and 13.3.5 (Prescribed time) shall not apply.
- 13.4 Law 13.4 shall be replaced with the following: the captains shall toss for the choice of innings on the field of play in the presence of one or both of the umpires not earlier than 45 minutes, nor later than 15 minutes, before the scheduled or any rescheduled time for the match to start. Law 13.5 shall apply (notification of decision to bat or bowl).
- 13.5 Uninterrupted Matches
- (a) Each team shall bat for 50 overs unless all out earlier or a result is achieved. A team shall not be permitted to declare its innings closed.
  - (b) If the team fielding first fails to bowl the required number of overs by the scheduled time for cessation of the first innings, play shall continue until the required number

of overs has been bowled. The team batting second shall receive its full quota of 50 overs irrespective of the number of overs it bowled in the scheduled time for the cessation of the first innings.

- (c) If the team batting first is dismissed in less than 50 overs the team batting second shall be entitled to bat for 50 overs.
- (d) If the team fielding second fails to bowl 50 overs by the scheduled cessation time, the hours of play shall be extended until the required number of overs has been bowled or a result is achieved.
- (e) Penalties shall apply for slow over rates – per playing condition 13.10.

#### 13.6 Delayed or Interrupted Matches

- (a) Delay or interruption to innings of team batting first
  - (i) When playing time has been lost the revised number of overs to be bowled in the match shall be based on the rate of 15.38 overs per hour in the total remaining time available for play.
  - (ii) The revision of the number of overs should ensure, whenever possible, that both teams have the opportunity of batting for the same number of overs. The team batting second shall not bat for a greater number of overs than the first team unless the latter completed its innings in less than its allocated overs.
  - (iii) A fixed time will be specified for the commencement of the interval, and also the close of play for the match, by applying the over rate per hour as defined in (i) above. When calculating the length of playing time available for the match (otherwise known as Remaining Playing Time), or the length of innings, the timing and duration of all relative delays, extensions in playing hours, interruptions in play, and intervals, excluding those for drinks, will be taken into consideration. This calculation must not cause the match to finish earlier than the original time for cessation of play. If required the original time shall be extended to allow for one extra over per team. To constitute a match, a minimum of 25 overs have to be bowled to the side batting second, subject to a result not being achieved earlier.
  - (iv) Remaining Playing Time does not include the time of the interval as calculated per playing condition 11.2.
  - (v) If the team fielding first fails to bowl the revised number of overs by the specified time for the interval, play shall continue until the required number of overs have been bowled or the innings is completed.
  - (vi) Should calculations regarding numbers of overs result in a fraction of an over, the fraction shall be ignored.
  - (vii) Penalties shall apply for slow over-rates – per playing condition 13.10.
  - (viii) The umpires shall calculate all details when an interruption or delay occurs to the first innings of the match by using the calculation sheet in Appendix 1.
- (b) Delay or interruption to innings of team batting second
  - (i) When playing time has been lost and, as a result, it is not possible for the team batting second to have the opportunity of receiving its allocated, or

revised allocation of overs in the playing time available, the number of overs shall be reduced at a rate of 15.38 overs per hour in respect of the lost playing time. Should the calculations result in a fraction of an over the fraction shall be ignored.

- (ii) In addition, should the innings of the team batting first have been completed prior to the scheduled, or re-scheduled time for the commencement of the interval, then the Remaining Playing Time shall take into account the time by which the second innings started early.
  - (iii) To constitute a match, a minimum of 25 overs have to be bowled to the team batting second subject to a result not being achieved earlier.
  - (iv) The team batting second shall not bat for a greater number of overs than the first team unless the latter completed its innings in less than its allocated overs.
  - (v) A fixed time will be specified for the close of play by applying a rate of 15.38 overs per hour. The timing and duration of all relative delays, extensions in playing hours and interruptions in play, will be taken into consideration in specifying this time.
  - (vi) If the team fielding second fails to bowl the revised overs by the scheduled or re-scheduled close of play, the hours of play shall be extended until the overs have been bowled or a result achieved.
  - (vii) Penalties shall apply for slow over rates – per playing condition 13.10.
  - (viii) The umpires shall calculate all details when an interruption or delay occurs to the second innings of the match by using the calculation sheet in Appendix 2.
- 13.7 No bowler shall bowl more than 10 overs in an innings. In a delayed or interrupted match where the overs are reduced for both teams or for the team bowling second, no bowler may bowl more than one-fifth of the total overs allowed. Where the total overs is not divisible by 5, one additional over shall be allowed to the maximum number per bowler necessary to make up the balance. Bowlers shall also be allowed to complete the remaining deliveries in any incomplete over.
- 13.8 In the event of a bowler breaking down or being suspended and being unable to complete an over, the remaining balls will be allowed by another bowler. Such part of an over will count as a full over only in so far as each bowler's limit is concerned.
- 13.9 The umpire shall record the total number of overs bowled and the number of overs bowled by each bowler.
- 13.10 Unless determined otherwise by the umpires, a penalty of six runs per over shall be awarded to the batting side for each over short of the required number at the scheduled, or rescheduled, cessation time for the innings. The over in progress at the cessation time shall count as a complete over prior to penalties being applied. This penalty will be applied at the completion of the innings.
- 13.11 The umpires of the match shall keep a full record of all allowances given and provide continual feedback throughout the innings where possible, to both captains, of the overs the innings is behind subject to playing condition 13.10.

## 14. THE FOLLOW-ON

---

Law 14 shall not apply.

## 15. DECLARATION AND FORFEITURE

---

Law 15 shall not apply.

## 16. THE RESULT

---

Law 16 shall apply, subject to the following:

16.1 Law 16.1 and 16.4 (agreement under Law 13.1.2) shall not apply.

16.2 Law 16.2 shall apply in addition to the following:

- (a) A result can be achieved only if both sides have had the opportunity of batting for at least 25 overs, unless one side has been all out in less than 25 overs or unless the team batting second scores enough runs to win in less than 25 overs.
- (b) All matches in which both teams have not had an opportunity of batting for a minimum of 25 overs, shall be declared a Draw.

The umpires shall refer to Appendix 3 for the latest possible times to start a match.

16.3 Law 16.5.1 shall apply in addition to the following:

- (a) In matches in which both sides have had the opportunity of batting for the agreed number of overs, the side scoring the higher number of runs shall be the winner.  
  
If the scores are equal, the result shall be a Tie and no account shall be taken of the number of wickets which have fallen.
- (b) In a Finals match, if the scores are equal the result shall be a Tie with the side finishing higher on the ladder being declared the winner.

16.4 Interrupted or Prematurely Terminated Matches - Calculation of the Target Score

(a) Interrupted Matches - Calculation of the Target Score

If, due to suspension of play after the start of the match, the number of overs in the innings of either side has to be revised to a lesser number than originally allotted (50 overs), then a revised target score (to win) should be set for the number of overs which the team batting second will have the opportunity of facing.

This revised target is to be calculated using the current Duckworth/Lewis method. The target set will always be a whole number and one run less will constitute a Tie.

(b) Prematurely Terminated Matches

If the innings of the side batting second is suspended (with at least 25 overs bowled) and it is not possible for the match to be resumed, the match will be decided by comparison with the D/L Par Score determined at the instant of the suspension by the Duckworth/Lewis method. If the score is equal to the par score, the match is a Tie.

Otherwise the result is a victory, or defeat, by the margin of runs by which the score exceeds, or falls short of, the Par Score.

- 16.5 For the purpose of the ladder and ranking for Finals, sides may be awarded points for each of the following outcomes:

Result	Result points	Total Points
Win	6	6
Loss	0	0
Draw (abandonment) / Tie	3	3

#### 16.6 Bonus Points

- (a) 2 bonus points for any team that achieves victory with a run rate 2.00 times that of the opposition.

**NOTE:** FOR THE TEAM BATTING SECOND TO GAIN 2 BONUS POINTS THE VICTORY MUST BE ACHIEVED BY THE END OF THE 25TH OVER (OR IN A REDUCED OVERS MATCH 50% OF THE REDUCED NUMBER OF DELIVERIES, ROUNDED UP TO THE NEXT DELIVERY AS REQUIRED).

- (b) 1 bonus point for any team that achieves victory with a run rate 1.25 times that of the opposition.

**NOTE:** FOR THE TEAM BATTING SECOND TO GAIN 1 BONUS POINT, THE VICTORY MUST BE ACHIEVED BY THE END OF THE 40TH OVER (OR IN A REDUCED OVERS MATCH 80% OF THE REDUCED NUMBER OF DELIVERIES, ROUNDED UP TO THE NEXT DELIVERY AS REQUIRED).

- (c) Where a side is all out, the number of overs to be used is the maximum number of overs that side was otherwise eligible to face.
- (d) Where matches are shortened and targets revised through the Duckworth/Lewis method, bonus run rates and bonus defensive targets are derived as a proportion of the revised target score and maximum overs.

## PART C: THE OVER, SCORING RUNS, DEAD BALL AND EXTRAS

### 17. THE OVER

---

Law 17 shall apply.

### 18. SCORING RUNS

---

Law 18 shall apply, subject to the following:

- 18.1 Law 18.6 shall apply with the following appendage: Penalty runs for slow over rates per playing condition 13.10 above shall also apply.

## 19. BOUNDARIES

---

Law 19 shall apply.

## 20. DEAD BALL

---

Law 20 shall apply.

## 21. NO BALL

---

Law 21.15 (Penalty for a No Ball) shall be amended by adding the following:

### 21.1 Free hit after a No Ball

- (a) The delivery after a No Ball shall be a free hit for whichever batsman is facing it.
- (b) If the delivery for the free hit is not a legitimate delivery (any kind of No Ball or Wide Ball) then the next delivery will become a free hit for whichever batsman is facing it.
- (c) For any free hit, the striker can be dismissed only under the circumstances that apply for a No Ball, even if the delivery for the free hit is called Wide Ball.
- (d) Field changes are not permitted for free hit deliveries unless there is a change of striker. Note however 21.2 below.
- (e) The bowler's end umpire will signal a free hit (after the normal No Ball signal) by extending one arm straight upwards and moving it in a circular motion.

21.2 If an umpire calls and signals "No Ball" because of an infringement of playing condition 28.1, the captain of the fielding side may only move the needed minimum of fielders from the restriction to any place on the field of play where the restriction does not apply. The captain of the fielding side however cannot use this playing condition to move other fielders that did not cause the infringement.

*E.g. If two fielders have caused the infringement, being outside the Fielding Restriction Area, both fielders can be moved to within the Fielding Restriction Area (deep mid-wicket to short cover, fine leg to slip). A third fielder at mid-off however cannot be moved to another position, such as mid-on.*

21.3 Law 21.10 shall not apply.

## 22. WIDE BALL

---

Law 22 shall apply with the following addition to Law 22.1:

22.1 To assist with the adjudication of off side wides, lines shall be drawn from the popping crease to the bowling crease, parallel with the return crease, measured 17 inches (43.18cm) from the return crease on both sides of the wicket, hereby referred to as "Off Side Wide Lines".

- (a) A delivery passing the striker on the off side outside the Off Side Wide Line shall be a Wide provided he/she maintains a normal batting position and has not brought the ball within reach. If, in the opinion of the umpire, the striker has brought the ball within reach, the Off Side Wide Line shall be disregarded and the umpire shall apply a general interpretation consistent with the normal operation of Law 22.

- (b) A delivery on the leg side is to be called a Wide if it passes to the leg side of the striker's stumps and the striker's body.

22.2 A delivery is not to be called a wide if:

- (a) Law 22.4 applies;
- (b) The delivery passes to the leg side of the striker's stumps between the stumps and the striker's body;
- (c) The ball makes contact with the striker's bat or person;
- (d) The striker is attempting to play, or has aborted an attempt to play, a reverse sweep or switch hit. In this scenario only a delivery passing the striker outside the Off Side Wide Line on the leg side shall be a Wide.

## 23. BYE AND LEG BYE

---

Law 23 shall apply.

# PART D: FIELDERS AND SUBSTITUTES, BATSMEN AND RUNNERS, PRACTICE ON THE FIELD, WICKET-KEEPER

## 24. FIELDER'S ABSENCE; SUBSTITUTES

---

Law 24 shall apply.

## 25. BATSMAN'S INNINGS; RUNNERS

---

Law 25 shall apply.

## 26. PRACTICE ON THE FIELD

---

Law 26 shall apply.

## 27. THE WICKET-KEEPER

---

Law 27 shall apply.

## 28. THE FIELDER

---

Law 28 shall apply, subject to the following:

28.1 The following fielding restrictions shall apply at the instant of delivery:

- (a) There may not be more than 5 fielders on the leg side.
- (b) PowerPlay 1: During Overs 1-10 no more than two (2) fielders shall be permitted to be outside the fielding restriction area as depicted in playing condition 7.3. No stationary catchers are required.
- (c) PowerPlay 2: During Overs 11-40 no more than four (4) fielders shall be permitted to be outside the fielding restriction area as depicted in playing condition 7.3. No stationary catchers are required.
- (d) PowerPlay 3: During Overs 41-50 no more than five (5) fielders shall be permitted to be outside the fielding restriction areas as depicted in playing condition 7.3. No stationary catchers are required.

In the event of an infringement of any of the above fielding restrictions, either umpire shall call and signal "No Ball". See also playing condition 21.2 above.

28.2 In circumstances when the number of overs of the batting team is reduced, the number of overs within each phase of the innings shall be reduced in accordance with the table below. For the sake of clarity, it should be noted that the table shall apply to both the first & second innings of the match.

Total Overs	PP1	PP2	PP3
25	5	15	5
26	5	16	5
27	6	16	5
28	6	17	5
29	6	17	6
30	6	18	6
31	6	19	6
32	7	19	6
33	7	20	6
34	7	20	7
35	7	21	7
36	7	22	7
37	8	22	7
38	8	23	7
39	8	23	8
40	8	24	8
41	8	25	8
42	9	25	8
43	9	26	8
44	9	26	9



45	9	27	9
46	9	28	9
47	10	28	9
48	10	29	9
49	10	29	10

If play is interrupted during an innings and the table above applies, the PowerPlay takes immediate effect. For the avoidance of doubt this applies even if the interruption has occurred mid-over.

- 28.3 At the commencement of PowerPlay 2 and PowerPlay 3, the umpire shall signal such commencement to the scorers by rotating his/her arm in a large circle.

## PART E: APPEALS AND DISMISSALS

### 29. THE WICKET IS DOWN

---

Law 29 shall apply.

### 30. BATSMAN OUT OF HIS/HER GROUND

---

Law 30 shall apply.

### 31. APPEALS

---

Law 31 shall apply.

### 32. BOWLED

---

Law 32 shall apply.

### 33. CAUGHT

---

Law 33 shall apply.

### 34. HIT THE BALL TWICE

---

Law 34 shall apply.

### 35. HIT WICKET

---

Law 35 shall apply.

## 36. LEG BEFORE WICKET

---

Law 36 shall apply.

## 37. OBSTRUCTING THE FIELD

---

Law 37 shall apply.

## 38. RUN OUT

---

Law 38 shall apply.

## 39. STUMPED

---

Law 39 shall apply.

## 40. TIMED OUT

---

Law 40 shall apply.

# PART F: UNFAIR PLAY

## 41. UNFAIR PLAY

---

Law 41 shall apply, subject to the following:

- 41.1 Law 41.6 (Bowling of Dangerous and Unfair Short Pitched Deliveries) shall be replaced by the following:
- (a) A bowler shall be limited to one fast short pitched delivery per over.
  - (b) A fast short pitched delivery is defined as a ball, which after pitching, passes or would have passed above the shoulder height of the striker standing upright at the crease.
  - (c) The umpire at the bowler's end shall advise the bowler and the batsman on strike when each fast short pitched delivery has been bowled.
  - (d) In addition, for the purpose of this playing condition and subject to playing condition (f) below, a ball that passes above head height of the batsman, that prevents him/her from being able to hit it with his/her bat by means of a normal cricket stroke shall be called a Wide.
  - (e) For the avoidance of doubt any fast short pitched delivery that is called a Wide under this playing condition shall also count as one of the allowable short pitched deliveries in that over.
  - (f) In the event of a bowler bowling more than one fast short pitched delivery in an over as defined in playing condition (b) above, the umpire at the bowler's end shall call and signal "No Ball" on each occasion. A differential signal shall be used to signify a

fast short pitched delivery. The umpire shall call and signal “No Ball” and then tap the head with the other hand.

- (g) If a bowler delivers another fast short pitched ball in an over, the umpire, after the call of No Ball and when the ball is dead, shall caution the bowler, inform the other umpire, the captain of the fielding side and the batsmen at the wicket of what has occurred. This caution shall apply throughout the innings.
- (h) If there is a second instance of the bowler being no balled in the innings for bowling more than one fast short pitched delivery in an over, the umpire shall advise the bowler that this is his/her final warning for the innings. The umpire will also inform the other umpire, the captain of the fielding side and the batsmen at the wicket of what has occurred.
- (i) Should there be any further instance by the same bowler in that innings, the umpire shall call and signal “No Ball” and when the ball is dead direct the captain to take the bowler off forthwith. If necessary, the over shall be completed by another bowler, who shall neither have bowled the previous over, or part thereof, nor be allowed to bowl the next over, or part thereof.
- (j) The bowler thus taken off shall not be allowed to bowl again in that innings.
- (k) The umpire will report the occurrence to the other umpire, the batsmen at the wicket and as soon as possible to the captain of the batting side.
- (l) The umpires will then report the matter to the CCB using their match form, who shall take such action as is considered appropriate against the captain and the bowler concerned. Refer also to Law 41.1 - Fair and unfair play – responsibility of captains.

## 42. PLAYERS’ CONDUCT

---

Law 42 will apply, subject to the following:

- 42.1 Laws 42.4.2.3.1 and 42.4.2.3.2 shall vary as follows. The player shall be suspended for 15 overs.

## APPENDIX 1 – IN EVENT OF DELAY OR INTERRUPTION TO FIRST INNINGS

---

A. Net playing time available at start of match?	390
B. Time innings in progress?	_____
C. Playing time lost?	_____
D. Extra time available?	0
E. Time made up from reduced interval?	_____
F. Effective playing time lost $\{C - (D + E)\}$	_____
G. Remaining playing time available $\{A - F\}$	_____
H. <b>1</b> - Minutes per over?	3.9
H. <b>2</b> - Overs calculated to two decimal places $\{G / H1\}$	_____
I. <b>1</b> - Max overs per team $\{H2 / 2, \text{rounded up}\}$	_____
I. <b>2</b> - Max overs per bowler $\{I1 / 5\}$	_____
J. First session to commence or recommence?	_____
K. Length of innings $\{I1 * H1\}$	_____
L. Rescheduled first innings cessation time $\{J + (K - B)\}$	_____
M. Length of Interval?	_____
N. Second innings commencement time $\{L + M\}$	_____
O. Rescheduled second innings cessation time $\{N + K\}$	_____

Ensure that the match is not finishing earlier than the original or rescheduled cessation time. If so, use add an additional over or more to  $\{I1\}$ .

### Check whether an interruption during the first innings should terminate the innings:

P. Proposed re-start time $\{\text{Same as } J\}$	_____
Q. Rescheduled cut-off time allowing for full use of any extra time	_____
R. Remaining playing time $\{P \text{ to } Q\}$	_____
S. Potential overs to be bowled $\{R / H1\}$	_____
T. Number of completed overs faced to date in first innings	_____

If S is less than or equal to T, terminate first innings and begin with second innings. Complete calculation sheet below.

### Calculation sheet for the start of the second Innings:

A. <b>1</b> - Overs to be bowled $\{\text{Same as } S\}$	_____
B. Scheduled length of innings in minutes $\{S * H1, \text{rounded up}\}$	_____
C. Start time $\{\text{Same as } J \text{ and } P\}$	_____
D. Scheduled cessation time $\{C + B\}$	_____
A. <b>2</b> - Max overs per bowler $\{A1 / 5\}$	_____

## APPENDIX 2 – IN EVENT OF DELAY OR INTERRUPTION TO SECOND INNINGS

---

A. Time at start of innings	_____
B. Time at start of interruptions	_____
C. Time innings in progress in minutes {A to B}	_____
D. Restart time	_____
E. Length of interruptions {D - B}	_____
F. Additional time available:	_____
G. Total playing time lost {E - F}	_____
H. <b>1</b> - Maximum overs at start of innings	_____
H. <b>2</b> - Minutes per over	3.9
I. Overs lost {G / H2, rounded down}	_____
J. Adjusted maximum over length of innings {H1 - I}	_____
K. Rescheduled length of innings {J x H2, rounded up}	_____
L. Amended cessation time of innings {D + (K - C)}	_____
M. Maximum overs per bowler {J/5}	_____

## APPENDIX 3 – LATEST POSSIBLE START TIMES

---

*The following appendix uses the original cessation times as defined in playing condition 12.2 above. In the event the CCB changes the times of play, appropriate changes must also be made to this appendix.*

The latest a match can start or restart:

- In the event of a delayed start to the match:
  - 188 minutes of **Remaining Playing Time** is available for use. The match shall begin {188 minutes + 20 minutes for interval} before the scheduled cessation time of 6.00pm. I.e. 2.24pm for a 25 over a side match.
- In the event of a delayed start to the side batting second:
  - 98 minutes of **Remaining Playing Time** is available for use. The match shall restart before the scheduled cessation time of 6.00pm. I.e. 4.23pm for the side batting second to receive 25 overs.

**Note:** *In this scenario, the match scheduled cessation time shall be 6.01pm. If the match was possible to restart at 4.22pm, it is theoretically possible to get 26 overs in by the scheduled cessation time.*

## SPIRIT OF CRICKET

---

Cricket owes much of its appeal and enjoyment to the fact that it should be played not only according to the Laws, but also within the Spirit of Cricket.

The major responsibility for ensuring fair play rests with the captains, but extends to all players, umpires and, especially in junior cricket, teachers, coaches and parents.

Respect is central to the Spirit of Cricket:

- Respect your captain, team-mates, opponents and the authority of the umpires.
- Play hard and play fair.
- Accept the umpire's decision.
- Create a positive atmosphere by your own conduct, and encourage others to do likewise.
- Show self-discipline, even when things go against you.
- Congratulate the opposition on their successes, and enjoy those of your own team.
- Thank the officials and your opposition at the end of the match, whatever the result.

Cricket is an exciting game that encourages leadership, friendship and teamwork, which brings together people from different nationalities, cultures and religions, especially when played within the Spirit of Cricket.

© Marylebone Cricket Club